



Screw Pin "Wide Body" Shackles

Crosby is pleased to announce that selected sizes of the "Original" Wide Body shackles are now available in a screw pin design.

Crosby's "Wide Body" Shackles provide the following benefits:

- Significantly improves the life of wire rope slings.
- Can be used to connect HIGH STRENGTH Round Slings, Synthetic Round Slings or Wire Rope Slings.
- Increase in shackle bow radius provides minimum 58% gain in sling bearing surface.
- Increases usable sling strength a minimum of 15%.

Product features:

- Capacities of 7, 12.5 and 18 metric tonnes
- Quenched and Tempered for maximum strength
- Forged Alloy Steel
- Available in galvanized and self colored finish
- Individually proof tested and magnetic particle inspected. Crosby certification available at time of order.
- Crosby products meet or exceed all requirements of ASME B30.26 including identification, ductility, design factor, proof load and temperature requirements. Importantly, Crosby products meet other critical performance requirements including fatigue life, impact properties and material traceability, not addressed by ASME B30.26.
- 18t has DNV Type Approval to Rules for Certification of Lifting Appliances, and is produced in accordance with DNV MSA requirements. Databook is provided that includes required documents.
 - Serialization / Identification
 - Material Testing (Physical / Chemical / Charpy)
 - Proof Testing

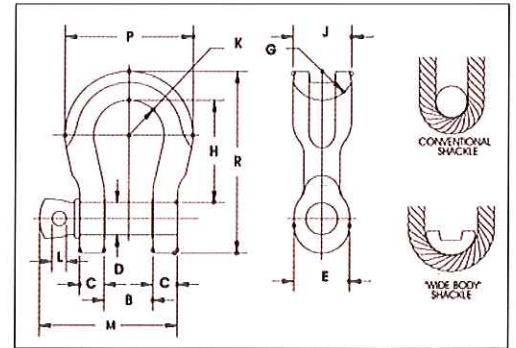

Working Load Limit (t)*	G-2169 Stock No.	S-2169 Stock No.	Weight Each (lbs.)	Dimensions (in.)											
				B +/- .25	C	D +/- .02	E	G	H	J	K	L	M	P	R
7	1021655	1021664	3.5	1.25	.69	.88	1.82	1.25	3.56	1.60	1.25	.50	3.97	4.10	5.87
12.5	1021673	1021682	8.8	1.69	.92	1.13	2.38	1.37	4.63	2.13	1.63	.56	5.13	5.51	7.63
18	1021691	1021699	13	2.03	1.16	1.38	2.69	1.50	5.81	2.50	2.00	.69	6.25	6.76	9.38

* Ultimate Load is 5 times the Working Load Limit. Forged Alloy Steel. Proof Load is 2 times the Working Load Limit.

Working Load Limit (t)*	G-2169 Stock No.	S-2169 Stock No.	Weight Each (kg)	Dimensions (mm)											
				B +/- 6.35	C	D +/- .5	E	G	H	J	K	L	M	P	R
7	1021655	1021664	7.7	31.8	17.5	22.4	46.2	31.8	90.4	40.6	31.8	12.7	101	104	149
12.5	1021673	1021682	19.4	42.9	23.4	28.7	60.5	34.8	118	54.1	41.4	14.2	130	140	194
18	1021691	1021699	28.7	51.6	29.5	35.1	68.3	38.1	148	63.5	50.8	17.5	159	172	238

* Ultimate Load is 5 times the Working Load Limit. Forged Alloy Steel. Proof Load is 2 times the Working Load Limit.



thecrosbygroup.com

9992012

Crosby U.S.A.
 P.O. Box 3128
 Tulsa, OK 74101
 U.S.A.
 Sales Office: (918) 834-4611
 Fax: (918) 832-0940
crosbygroup@thecrosbygroup.com



Bishop Lifting Products, Inc.

www.Lifting.com